

MSI PC/104 Embedded PC Series

MSI-P710 ZigBee Wireless Card with Analog In and Digital I/O

FEATURES

- ◆ ZigBee advanced mesh networking functionality.
- ◆ Indoor/urban Range: Up to 300' (90 m).
- ◆ Outdoor line-of-sight Range: Up to 1 mile (1.6 km).
- ◆ Transmit Power Output: 50 mW (17 dBm).
- ◆ Operating Frequency: 2.4 GHz.
- ◆ RF Data Rate: 250,000 bps.
- ◆ Receiver Sensitivity: -102 dBm (1% PER).
- ◆ Serial Port: Selectable for COM1 thru COM4 with optional 16-bit offset address.
- ◆ ZigBee Analog Inputs: 4 selectable 10-bit channels.
- ◆ ZigBee TTL digital I/O: 5 selectable as input or output.
- ◆ Antenna Connection: RPSMA connector.
- ◆ Address and interrupt options: Jumper selectable.
- ◆ Operating temperature range: -40° C to 85° C.
- ◆ Warranty: One-year warranty from date of shipment.

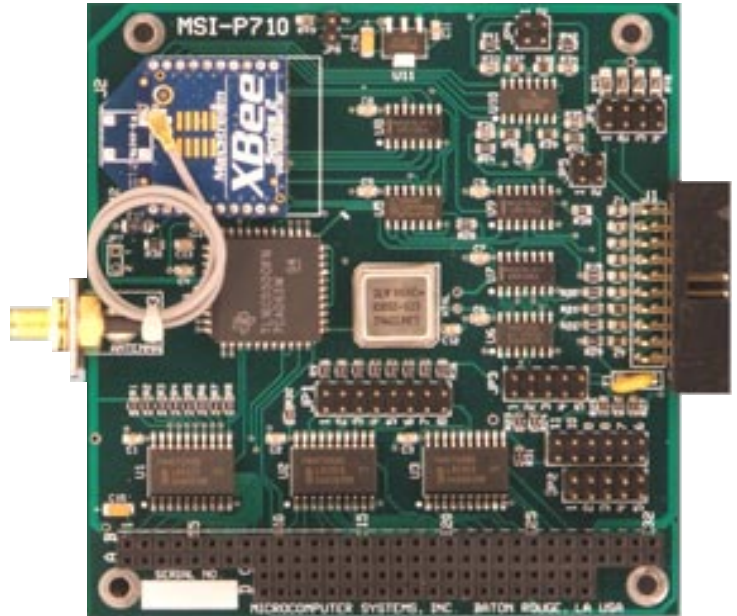

for greater node density. The card is configurable for Transparent or API operation. Uses simple AT commands with a standard COM port provided by an onboard UART. The card can function as a Coordinator, a Router or an End Device in the ZigBee mesh topology.

DESCRIPTION

The MSI-P710 is a low cost, high performance wireless card providing the ZigBee protocol using a XBee ZB or XBee-PRO ZB modules operating at an rf frequency of 2.4 GHz. With advanced mesh networking functionality, XBee and XBee-PRO ZB modules improve data traffic management and allow

A 16C550 UART interfaces the XBee module to the PC/104 bus. The UART provides a 16 byte transmit and receive FIFO and baud rates are programmable from 1200 to 115,200 bits/s. Automatic hardware RTS and CTS flow control is used to prevent overflow

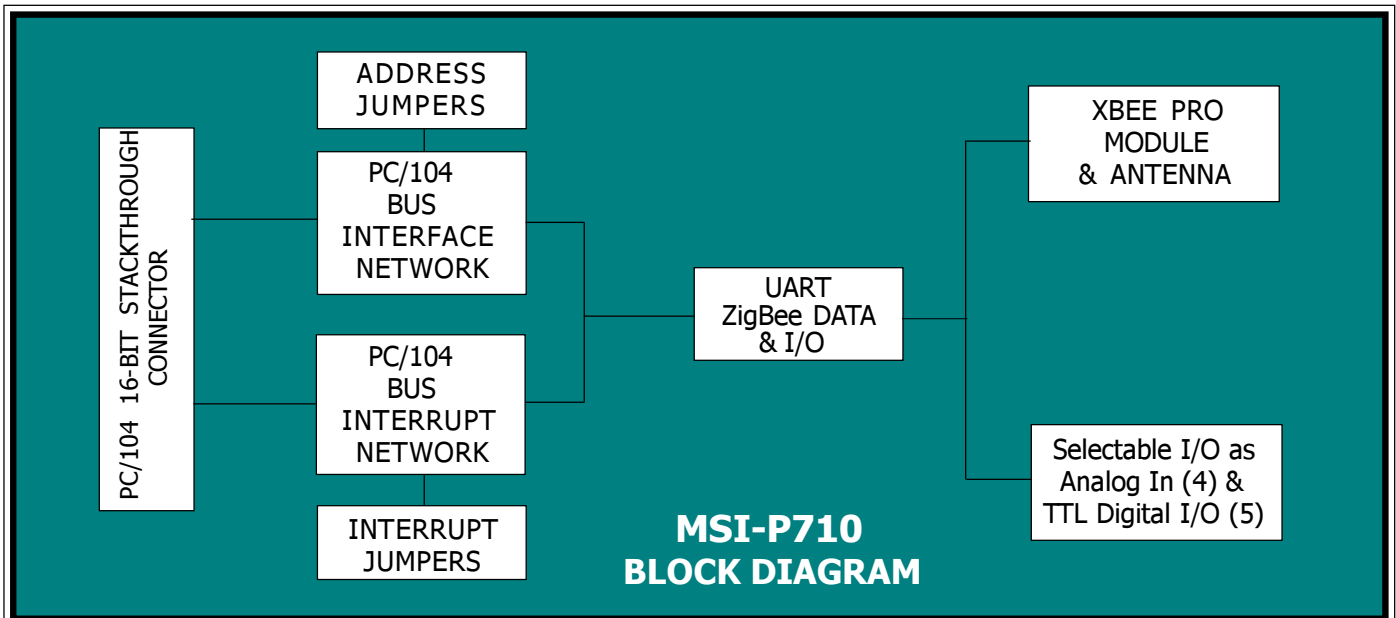

of the local receiver and remote receiver FIFOs. The card I/O address is jumper selectable for COM1 thru COM4 with an optional 16-bit offset address. Ten interrupts are jumper selectable for ranges contained in IRQ2 thru IRQ15.

The ZigBee I/O provides 4 lines of analog inputs individually selectable for 0-5V, 0-10V or 0-20mA with 10-bit resolution, and 5 TTL selectable as input or output. A fused 5V@0.5A is provided on the I/O connector is available for powering analog and digital sensors connected to the card. All I/O lines have varistor surge suppressors for transient voltage (lightning, etc.) protection.

The antenna connection to the card is provided by a RPSMA bulkhead connector. A 6" cable attaches this connector to the rf module which permits its removal from the card bracket for mounting into the user enclosure as an option.

A sample BASIC test program is supplied that illustrates programming of the card for various XBee ZigBee commands. A BASIC interpreter for running this program is available at no charge.

SPECIFICATIONS

PC/104 Bus 16-bit, stackthrough

XBee PRO Module

Indoor/urban Range: Up to 300' (90 m).

Outdoor Range: Up to 1 mile (1.6 km) line-of-sight.

Transmit Power Output: 50 mW (17 dBm)
Int'l. 10mW (10 dBm)

Operating Frequency: 2.4 GHz.

RF Data Rate: 250,000 bps.

Receiver Sensitivity: -102 dBm (1% PER).

ZigBee Analog Inputs: 4 selectable 10-bit channels, 0-5V, 0-10V, 0-20mA ranges.

ZigBee TTL digital I/O: 5 selectable as TTL input or output.

Serial Port

UART: 16C550

I/O Address: Jumper selectable as COM1 thru COM4 with an optional 16-bit offset.

Interrupts: Jumper selectable for IRQ3 thru IRQ5, IRQ7 and IRQ9 thru IRQ15. Selectable 1K pull-down resistor.

I/O Connectors

3M 30320-5002

Option Jumpers

.025" square posts, 0.1" grid

Electrical & Environmental

+5V @ 70 mA typical, idle/receive mode

+5V @ 205 mA typical, transmit mode (10 dBm)

+5V @ 285 mA typical, transmit mode (18 dBm)

+5V @ 45 mA typical, power save mode

Operating Temperature: -40° to 85° C

Ordering Information

MSI-P710 AIO & DIO w/RPSMA bulkhead

MSI-P710-X Excludes I/O w/RPSMA bulkhead

Accessories

MSI-WiPort-Ant

Omni-directional "Rubber Duck" antenna, 2.4 GHz, 3 dBi, Reverse Polarity SMA.



MICROCOMPUTER SYSTEMS, INC.

1814 Ryder Drive ♦ Baton Rouge, LA 70808 ♦ Phone (225) 769-2154 ♦ Fax (225) 769-2155
Email: staff@microcomputersystems.com <http://www.microcomputersystems.com>